





TRANSCRAFT EAGLE® II

Eagle II Standard Specifications

Front Plate	High Strength Aluminum 6 1/2" deep, square corners, no stake pockets.				
Rear Plate	1/4" Thick High Strength Extruded Aluminum, 13" deep boxed section with internal stake pockets and recessed lites with back fully enclosed. 11 1/4" deep extra heavy duty rubber dock bumpers along with a 4" x 5" tubing bumper and heavy duty bracing provide maximum protection for the rear of the trailer. NOTE: 96" wide trailers will have a hi-tensile steel rear plate.				
5th Wheel Plate	SAE King pin @ 30" location, 1/4" skid plate tapers up front for easy pickup. 24" or 36" location optional.				
Main Beam (Lightening holes in web)	42'	45'	48'	53'	
	Extreme Duty	1/2"	1/2"	1/2"	1/2"
80,000 in 10'	1/4"	1/4"	1/4"	1/4"	Web
73,000 in 4'	1/2"	1/2"	1/2"	1/2"	Bottom Flange
GVWR 80,000	130k	130k	130k	130k	Material
Heavy Duty (Std)	3/8"	3/8"	7/16"	1/2"	Top Flange
70,000 in 10'	3/16"	3/16"	3/16"	3/16"	Web
65,000 in 4'	7/16"	7/16"	7/16"	1/2"	Bottom Flange
GVWR 80,000	130k	130k	130k	130k	Material
Standard Duty	3/8"	3/8"	3/8"	7/16"	Top Flange
60,000 in 10'	3/16"	3/16"	3/16"	3/16"	Web
55,000 in 4'	3/8"	3/8"	3/8"	7/16"	Bottom Flange
GVWR 73,000	>100k	>100k	>100k	>100k	Material
Upper Frame	4" Steel Jr. I Sills, 12" O/C.				
Lower Frame	Steel Pipe Braces as required running from bottom of sills to main beams with lower inner cross pipes between beams from landing gear to rear on approximately 2' centers.				
Side Rail	5 1/2" Aluminum Side Rail, 5/16" thick stake pockets, 1 5/8" x 3 1/2" x 4" Deep, 24" O/C, 3/8 x 3" rubrail with recess for reflective tape, 2" alum. double spools.				
Landing Gear	Premium Jost A400 gear, 160,000# static load rated legs with 10" x 10" square cushion foot.				

Suspension	Hendrickson AANT 23k "Intraax" Airide with "Quick-Align" feature. Suspension set at rear most position.
Axles	Integral axle, extended service brake linings, "P" Spindle, Haldex Automatic Slack Adjusters. type 3030 spring brakes.
Hub, Brake Drum, & Wheels	8.25-22.5 hub piloted 10 hole steel disc painted white. Cast hubs, outboard mounted cast drums.
Brakes	Premium Extended Service Brake lining, 16.5 x 7" with anti-lock braking sensors on every wheel. Meritor Wabco 4S2M ABS is used for maximum brake life and virtual elimination of flat spotted tires.
Electric	Male pin connectors to all lights with double seals. Locked in place with a positive retention pin to eliminate the biggest reason for wiring problems - loose connections. All required splices are sonic welded. All wires are double insulated in a sealed loom with molded double seals. This system was designed for Transcraft by USA Harness. Exclusive Grote male pin connection <u>LED lights are standard</u> for a total lifetime, trouble free, electrical system with a 5 year warranty on materials and labor. This system includes 25 lights, 2 on front, 5 on each side, 2 large 4" mid wide turn lights, 6 combination 4" rear lights, 3 round identification lights, ABS lamp, and an incandescent license light. There is a simple plug-in provision for accessory power.
Floor	1 1/8" Aluminum interlocking Planks with 4 Apitong Nailers.
Paint	Steel components are cleaned, phosphatized, and primed with a 2-part universal primer, then painted with a 2-part black urethane. Aluminum components are natural.
Reflective Tape	The highest quality 3M reflective tape is installed in the recess of the rubrail for protection, throughout the trailer except on the rear cross tube of bumper.
Trim	Eagle Anti-spray mud flaps behind rear axle.
Tires	295/75R 22.5 General Rib ST Load Range G.

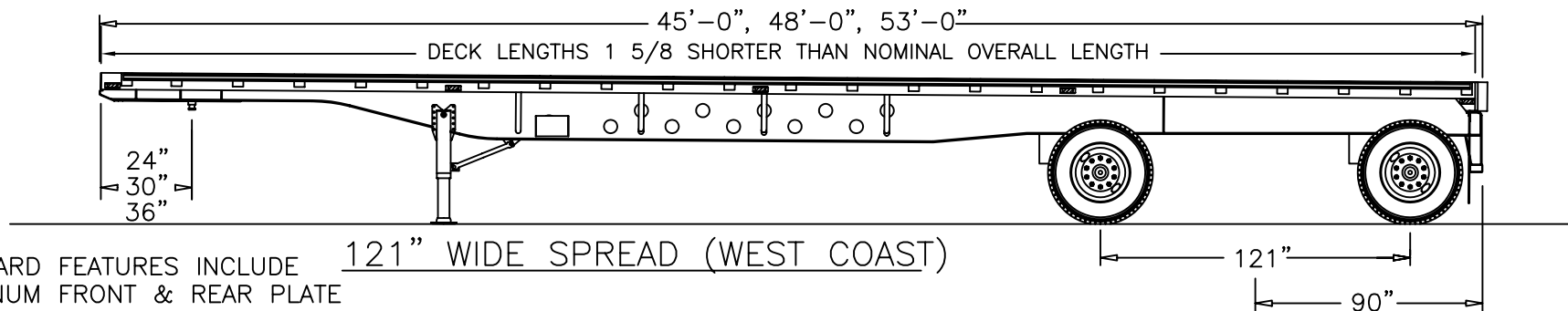
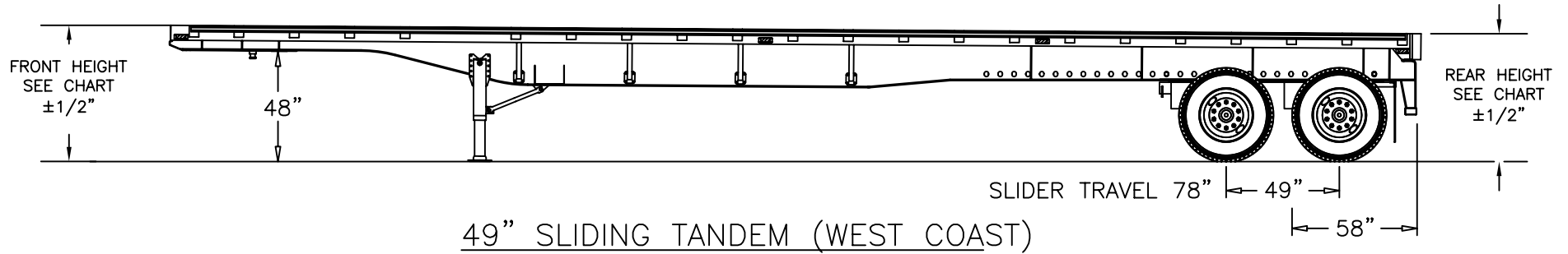
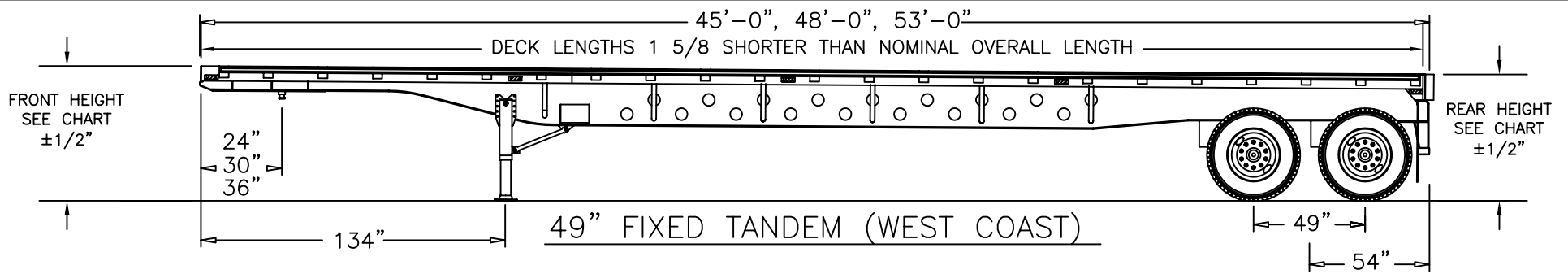

STANDARD FEATURES INCLUDE

- 121" WIDE SPREAD (WEST COAST)
- ALUMINUM FRONT & REAR PLATE
- ALUMINUM SIDE RAIL, POCKETS, DOUBLE SPOOLS
- 4" STEEL JR I-BEAM CROSSMEMBERS
- 6 STOP-TURN-TAIL COMBO LIGHTS ON REAR
- STEEL KNEE BRACES

REAR HEIGHT VARIES WITH TIRE DIAMETER AND SUSPENSION SETTING

LENGTH FEET	STANDARD FLANGE THICKNESS	SLIDING SUSPENSIONS		FIXED SUSPENSIONS	
		FRONT HEIGHT	REAR HEIGHT	FRONT HEIGHT	REAR HEIGHT
53	1/2	59 13/16	55 3/16	59 7/8	54 1/2
48	7/16	59 11/16	55	59 3/4	54 5/16
45	3/8-7/16	59 11/16	54 13/16	59 11/16	54 1/8

THE FOLLOWING TOLERANCES APPLY TO ALL DIMENSIONS UNLESS OTHERWISE SPECIFIED
FRACTIONAL: +/- 1/2"
DECIMAL: +/- .005"

Transcraft

DR. BY: SMG	NAME: EAGLE-II HEAVY DUTY SHOWN	REV: D
WEIGHT:	DATE: 08-01-01	P/N: S-148412
		SHEET 1 OF 1