





**TRANSCRAFT®**  
**DTL-3000™**

# DTL-3000 Standard Specifications

<b>Front Plate</b>	Fabricated Hi Tensile Steel, square corners, no stake pockets.
<b>Rear Plate</b>	Hi Tensile Steel, 13" deep section with internal stake pockets and recessed lites with back fully enclosed. 11 1/4" deep extra heavy duty rubber dock bumpers along with a 4" x 5" tubing bumper and heavy duty bracing provide maximum protection for the rear of the trailer.
<b>5th Wheel Plate</b>	SAE King pin, 30" location, 1/4" skid plate tapers up front for easy pickup. 24" or 36" location optional.
<b>Main Beam</b> (Lightening holes in web)	Built for maximum payload with a beam capacity of 85,000# in 10' or 80,000# in 4'. Assembled with heat treated 130,000# yield strength flanges and high tensile steel webs. GVWR 80,000# 1/2" x 5" 130K Flanges 3/8" G. N. & 1/4" Web
<b>Upper Frame</b>	4" Jr I Sills, 12" O/C.
<b>Lower Frame</b>	Pipe Braces running from bottom of sills to main beams with matching inner cross pipe.
<b>Side Rail</b>	10 gauge fabricated Side Rail, 1 5/8" x 3 1/2" x 3 1/2" x 1/4" stake pockets, 3/8" x 2 1/2" rubrail with recess for reflective tape, double pipe spools between pockets.
<b>Landing Gear</b>	Premium Jost A400 gear, 160,000# static load rated legs with 10" x 10" square cushion foot.
<b>Suspension</b>	Intraax AA-230L Airide with "Quick-Align" feature. Suspension set at rear most position.
<b>Axles</b>	Integral axle with "P" spindle, type 3030 spring brakes, and Haldex automatic slack adjusters.

<b>Wheels</b>	8.25-22.5 hub piloted steel disc, outboard mounted cast hubs and drums.
<b>Brakes</b>	Premium Extended Service Brake lining, 16.5 x 7" with anti-lock braking sensors on every wheel. Meritor Wabco 4S2M ABS is used for maximum brake life and virtual elimination of flat spotted tires.
<b>Electric</b>	Male pin connectors to all lights with double seals. Locked in place with a positive retention pin to eliminate the biggest reason for wiring problems - loose connections. All required splices are sonic welded. All wires are double insulated in a sealed loom with molded double seals. This system was designed for Transcraft by USA Harness.  Exclusive Grote male pin connection <u>LED lights are standard</u> for a total lifetime, trouble free, electrical system with a 5 year warranty on materials and labor. This system includes 25 lights, 2 on front, 5 on each side, 2 large 4" mid wide turn lights, 6 combination 4" rear lights, 3 round identification lights, ABS lamp, and an incandescent license light. There is a simple plug-in provision for accessory power.
<b>Floor</b>	1 1/8" Apitong with Shiplapped Edges.
<b>Paint</b>	Steel components are cleaned, phosphatized, and primed with a 2-part universal primer, then painted with a 2-part black urethane.
<b>Reflective Tape</b>	The highest quality 3M reflective tape is installed in the recess of the rubrail for protection, throughout the trailer and on the rear cross tube of bumper.
<b>Tires</b>	255/70R22.5 General ST250LP

10' Beam Capacity		4' Beam Capacity	
49" Axle Spacing	121" Axle Spacing	49" Axle Spacing	121" Axle Spacing
80,000#	85,000#	75,000#	80,000#

REV	REVISION CHANGE DESCRIPTION	BY	DATE	ECN
-----	-----------------------------	----	------	-----

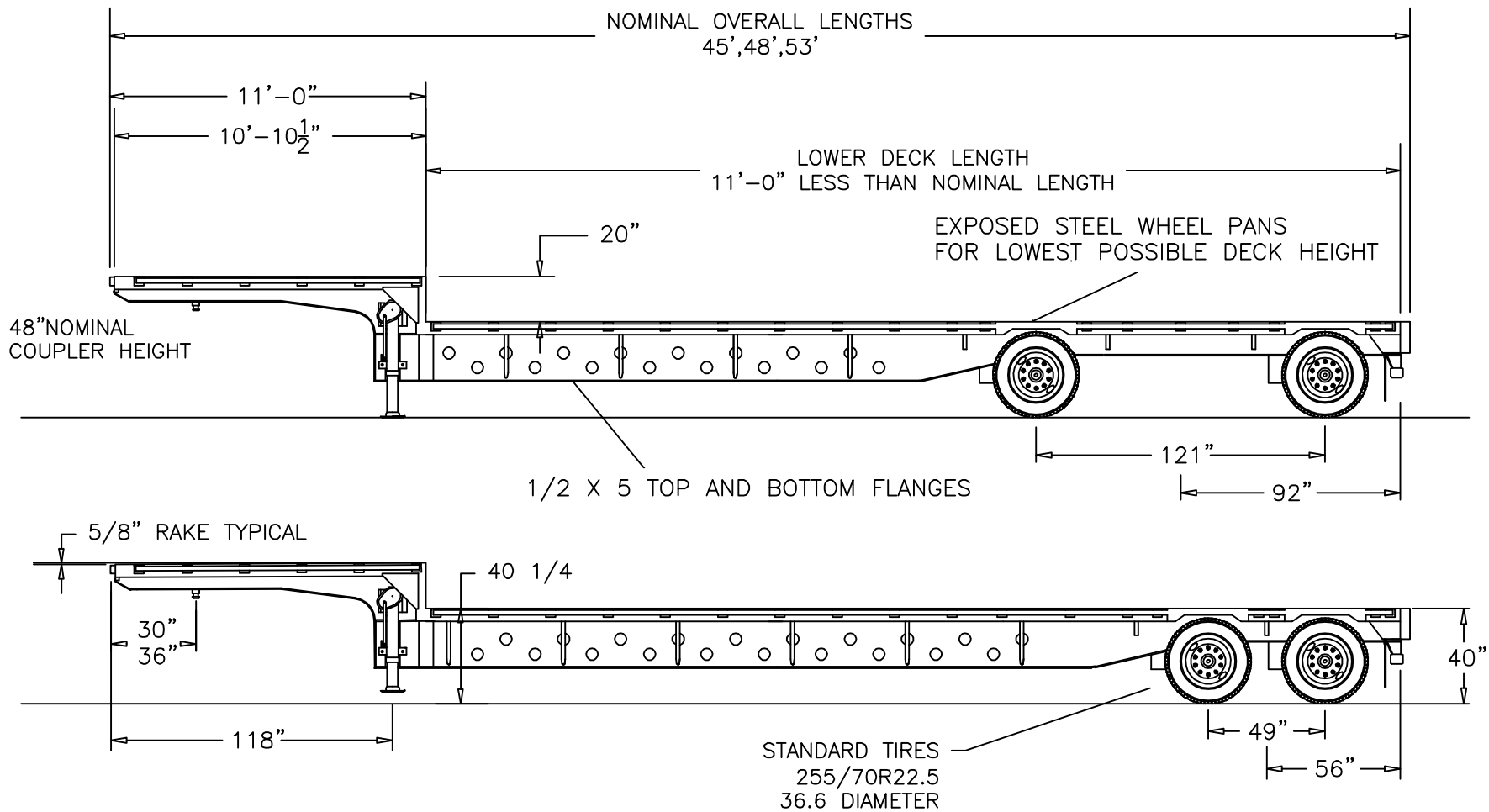

THE FOLLOWING TOLERANCES  
APPLY TO ALL DIMENSIONS  
UNLESS OTHERWISE SPECIFIED  
FRACTIONAL: +/- 1/2"  
DECIMAL: +/- .005"

*Transcraft*

DR. BY: SMG	NAME: DTL-3000	REV D
WEIGHT:	DATE: 7/18/03	P/N: S148372
		SHEET 1 OF 1